

AVERY DENNISON MARKETING SPECIFICATION

HISTORY

REV.	DATE	DESCRIPTION
A	08.06.08	RELEASED TO PRODUCTION
B	06.23.09	INCREASE CAPACITY; ADD NOTE 1; UPDATE TEMP RANGE
C	08.10.18	UPDATES TO NEW FORMAT; ADDED -0 TO PART NUMBER; ADDED SPECIAL CHARACTERISTIC NOTE

THE SUBJECT MATTER DISCLOSED HEREIN EMBODIES PROPRIETARY INFORMATION WHICH IS THE CONFIDENTIAL PROPERTY OF THE AVERY DENNISON CO. NONE OF WHICH SHALL BE COPIED, REPRODUCED, DISCLOSED TO OTHERS, PUBLISHED OR USED IN WHOLE OR IN PART, FOR ANY PURPOSE OTHER THAN THAT FOR WHICH IT IS BEING MADE AVAILABLE WITHOUT THE EXPRESS ADVANCE WRITTEN PERMISSION OF A DULY AUTHORIZED AGENT OF THE COMPANY. THIS DOCUMENT IS THE PROPERTY OF THE AVERY DENNISON CO. AND IS TO BE RETURNED TO THE COMPANY ON DEMAND.

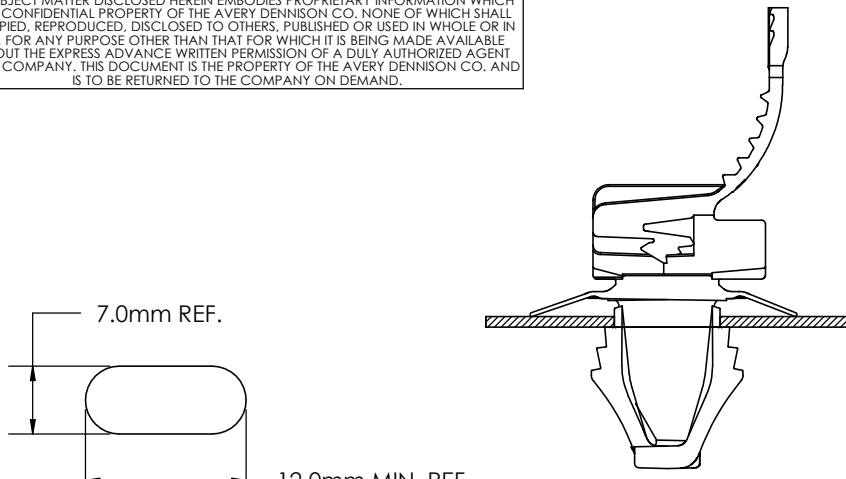

ASSEMBLED VIEW

MOUNTING HOLE

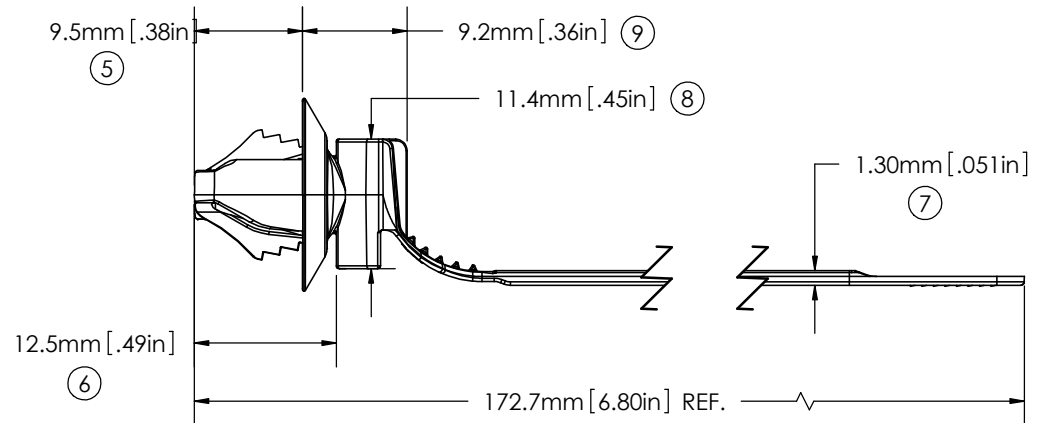
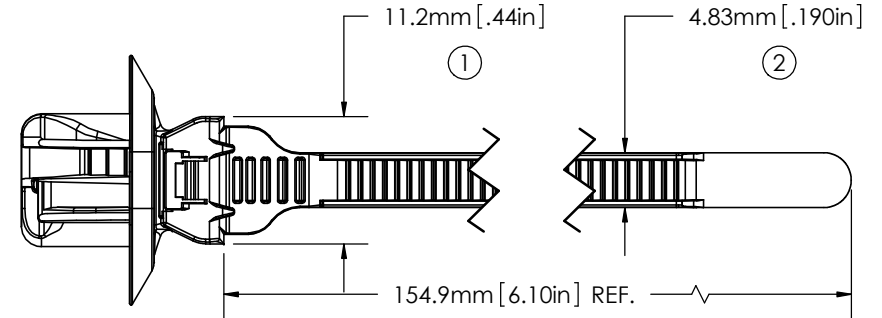
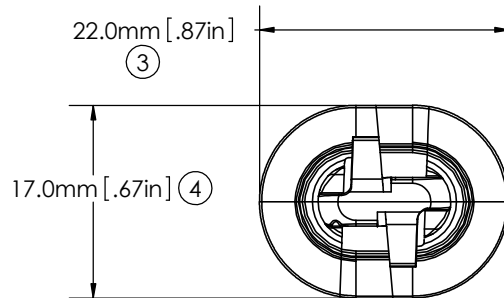

NOTES:

1. MATERIAL SHALL CONFIRM TO: WSK-M4D706-A, MS-DB-41 CPN1826, AND GMP.PA66.015

2. Δ = INDICATES SPECIAL CHARACTERISTIC

10	Δ	FLAMMABILITY:	HB RATED PER FMVSS302
11	Δ	TENSILE STRENGTH:	50 LBF / 222N MIN.
		MOUNTING:	7mm X12mm MIN. SLOTTED HOLE
		PANEL THICKNESS RANGE:	0.7mm TO 3.6mm THK.
		WEIGHT:	1.8g
		TEMPERATURE RANGE:	-40 °F (-40 °C) TO 239 °F (115 °C) CONTINUOUS AND 257 °F (125 °C) AT MAXIMUM EXPOSURE
		BUNDLE DIAMETER:	φ 1.6mm TO φ 38.1mm
		TOOL:	12001- HAND INSTALLATION TOOL 12500- PNUM. INSTALLATION TOOL
		TOOL TENSION SETTING:	6 - 8
		PACKAGING:	500/BAG, 10 BAGS/MASTER

APPROVALS:	ENG. APPR. <i>Daniel Gilbertson</i>	08.10.18
	Q.A. APPR. <i>Rick Estano</i>	08.10.18

SPECIFIED TOLERANCES ARE:

.XX ± .03 INCHES	.X ± .7mm
.XXX ± .010 INCHES	.XX ± .25mm
ANGULAR: ± 2°	

MATERIAL	NYLON 6/6, IMPACT MODIFIED, HEAT STABILIZED
COLOR	BLACK



FASTENER DIVISION
FITCHBURG, MA 01420 U.S.A.
TEL. 1-800-225-5913
FAX. 978-353-8157

DESCRIPTION	DIRECTIONAL SLOT TIE	
PART NO.	20115-0	REV. C